

# KPM (Sweep Frequency Response Analyzer) – KPM SFRA 01



## ***KPM- SFRA 01***

### ***A reliable and accurate SFRA testing solution .***

Sweep Frequency Response Analysis Test or in short SFRA Test can detect efficiently, displacement of transformer core, deformation and displacement of winding, faulty core grounds, collapse of partial winding, broken or loosen clamp connections, short circuited turns, open winding conditions etc.

#### **How SFRA works**

Transformers consist of multiple complex networks of capacitances and resistors that can generate a unique signature when tested at discrete frequencies and plotted as a curve. The distance between conductors of the transformer forms a capacitance. Any movement of the conductors or windings will change this capacitance. This capacitance being a part of complex L (inductance), R (Resistance) and C (Capacitance) network, any change in this capacitance will be reflected in the curve or signature.

An initial SFRA test is carried out to obtain the signature of the transformer frequency response by injecting various discrete frequencies. This reference is then used for future comparisons.

A change in winding position, degradation in the insulation, etc. will result in change in capacitance or inductance thereby affecting the measured curves. Tests are carried out periodically or during major external events like short circuits and results compared against the initial signature to test for any problems. Voltage transfer function  $U_o/U_i (f)$  SFRA test reveals if the transformers mechanical or electrical integrity has been compromised.

#### **SFRA analysis can detect problems in transformers such as:**

- winding deformation – axial & radial, like hoop buckling, tilting, spiraling
- displacements between high and low voltage windings
- partial winding collapse
- shorted or open turns
- faulty grounding of core or screens
- core movement
- broken clamping structures
- problematic internal connections

#### **Key Points:**

- ***Light weight & portable with integrated handle***
- ***Inbuilt Display***
- ***Rugged Design***
- ***Integrated thermal printer***

#### **. Uses**

- To obtain initial signature of healthy transformer for future comparisons
- Periodic checks as part of regular maintenance
- Immediately after a major external event like short circuit transportation or relocation of transformer
- Earthquakes
- Pre-commissioning check



# KPM (Sweep Frequency Response Analyzer) – KPM SFRA01

## Features :

1. Using the advanced technical of DDS;
2. Using the high speed and advanced microprocessor to design;
3. Using AD chip of 16 bits;
4. With seven inch LCD touch screen of which the brightness can be adjusted;
5. With thermal printer of which the print thick can be adjusted;
6. It could store one hundred and twenty groups of FRA data, fifty groups of SCI data and thirty groups of SCI data, which could be read to current screen or upload to the PC;
7. With PC software using which we could upload data ,test, analyze data, print data, or create word document;
8. Using USB2.0 to connect to the device;

## Specifications

Sweep frequency response :

- 1.1. Sweeping frequency method to measure winding deformation.

Scan frequency range: 10HZ-1MHZ (DLT911-2016 0.5KHZ interval linear scan)  
20HZ-2MHZ (GB/T-1094.18 IEC60076-18:2012 segmented scanning)  
10HZ-10MHZ (GB/T-1094.18 IEC60076-18:2012 segmented scanning)  
1KHZ -1000KHZ. \_1.0(Linear scan 1KHZ interval PC side available)  
1KHZ -1000KHZ. \_0.5(linear scan 0.5KHZ interval available for Pc)  
1KHZ -2000KHZ. \_1.0(linear scan 1KHZ interval available for PC)  
1KHZ -2000KHZ. \_0.5(linear scan 0.5KHZ interval available for PC)  
100HZ-1000K. (Segmented scan PC available 1441 points):  
100HZ-1KHZ 5HZ interval 180 points  
1KHZ-10KHZ 50HZ interval 180 points  
10KHZ-100KHZ 500HZ interval 180 points  
100KHZ-1000KHZ 1KHZ interval 901 points  
100HZ-2000K (Segmented scan PC available 2441 points)  
100HZ-1KHZ 5HZ interval 180 points  
1KHZ-10KHZ 50HZ interval 180 points  
10KHZ-100KHZ 500HZ interval 180 points  
100KHZ-1000KHZ 1KHZ interval 900 points  
1000KHZ-2000KHZ 1KHZ interval 1001

Points

Amplitude measurement range: (-100dB) - (+20dB)

Amplitude measurement accuracy: (-40dB) - (+20dB) 0.2dB

(-60dB) - (-40dB) 0.5dB

(-80dB) - (-60dB) 1.0dB

Angle measurement range: (-180°) - (+180°) (10HZ-2MHZ)



# KPM (Sweep Frequency Response Analyzer) – KPM SFRA 01

- Scan frequency accuracy: less than 0.01%
- Signal input impedance: greater than  $1M \Omega$  (DLT911-2016)
- $50 \Omega$  (GB/T-1094.18 IEC60076-18:2012)
- Signal output impedance:  $50 \Omega$ .
- Same-phase test repetition rate: 99.5%.

## Working conditions

- Operating voltage: AC220V  $\pm 10\%$
- Frequency: 50Hz  $\pm 10\%$
- Power consumption:  $\leq 60W$
- Use of ambient temperature:  $0 \sim 40^\circ C$
- Use of environmental humidity:  $\leq 90\% RH$
- Host volume: 520 X 290 X 220 mm<sup>3</sup>      Weight: 10kg

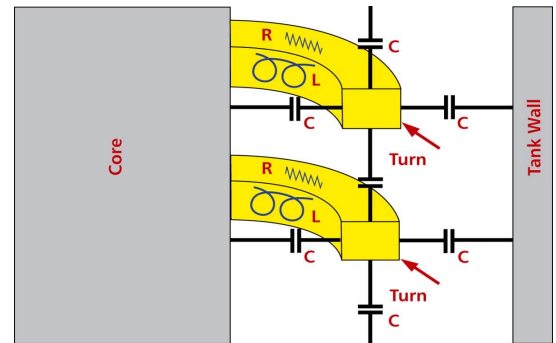

**Transformer** : A complex combination of Resistance ( R ) , Inductance ( L ) & Capacitance ( C )

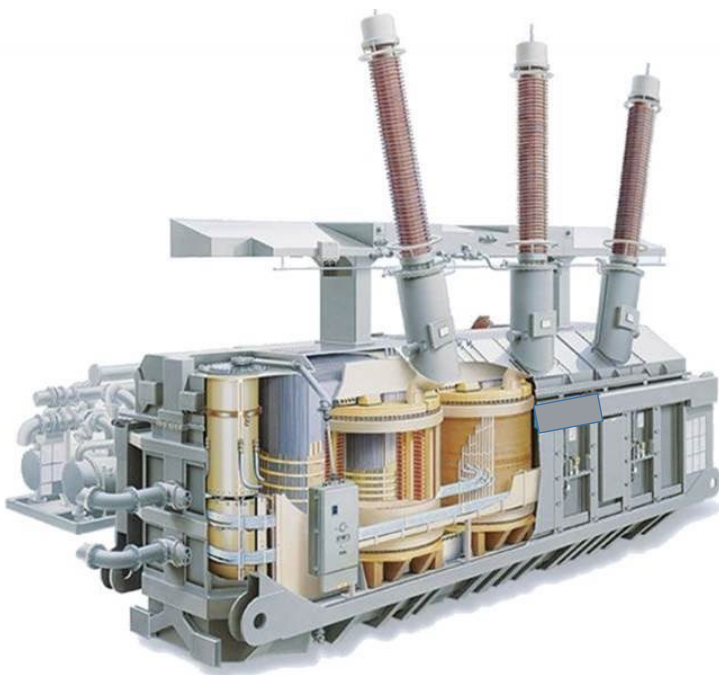

Any Movement inside Transformer changes the RLC equivalent which is Identified by KPM-SFRA01

## Contact Us

KPM ENGINEERING SOLUTIONS PVT. LTD.  
815 A, 8th Floor, Unitech Arcadia, Sec 49,  
Gurugram – 122018 ,Haryana  
Website : [www.kpmttek.com](http://www.kpmttek.com)  
Email : [info@kpmttek.com](mailto:info@kpmttek.com)  
Phone No : +91 124 4001088

